



Multijack-Up 2417 | Jack-up barge



The Multijack-Up is a multi-purpose jack-up barge design, which offers solutions to all kinds of maritime operations such as offshore construction. It can be modified to fit your demands. This could either be the installation of propulsion, or the installation of a heavy lift crane to fit your project.



CLASSIFICATION	Bureau Veritas I ✘ HULL • MACH Offshore Self Elevating Unit, Coastal Area, Transit over 20 miles from shore with HS < 2.5m
DIMENSIONS	
LENGTH O.A.	24,38 meters
BREADTH MLD.	17,08 meters
DEPTH AT SIDE	2,43 meters
DRAFT	1,89 meters
MOONPOOL	Ø 580 mm
OPERATING CONDITIONS	
MAX. DESIGN WATER DEPTH	25 meters
SPUD LEGS	
LENGTH	42,0 meters (30+12)
DIAMETER	1,2 meters
WEIGHT	38 tons
AUXILIARIES	
GENERATOR SETS	2x Perkins E70TAG2M
TOTAL E-POWER	240 kVA
FIFI	Certified fifi system
JACK-UP	Double acting jacking system

CAPACITY	
FUEL OIL	1000 liters
HYDRAULIC OIL	3600 liters
DECK LOAD	6 ton/m ²
JACKING PARAMETERS	
JACKING SPEED	17 m/hour
VARIABLE LOAD	300 tons
PRELOAD FORCE PER LEG	335 tons
PARAMETERS AT 16M DEPTH	
CURRENT VELOCITY	2,0 m/sec
WIND VELOCITY(SURVIVAL)	13 m/sec (30 m/sec)
SIGNIF. WAVE HEIGHT (SURVIVAL)	2,0 meters (4,0 meters)
MAX. WAVE HEIGHT (SURVIVAL)	3,72 meters (7,44 meters)
PARAMETERS AT 20M DEPTH	
CURRENT VELOCITY	2,0 m/sec
WIND VELOCITY (SURVIVAL)	13 m/sec (30 m/sec)
SIGNIF. WAVE HEIGHT (SURVIVAL)	2,0 meters (2,5 meters)
MAX. WAVE HEIGHT (SURVIVAL)	3,72 meters (4,65 meters)
OPTIONS	
MODULAR CONSTRUCTION	21 containers of 20" and 40"
POSITIONING SYSTEM	4-point mooring system
ACCOMMODATION	Modular units

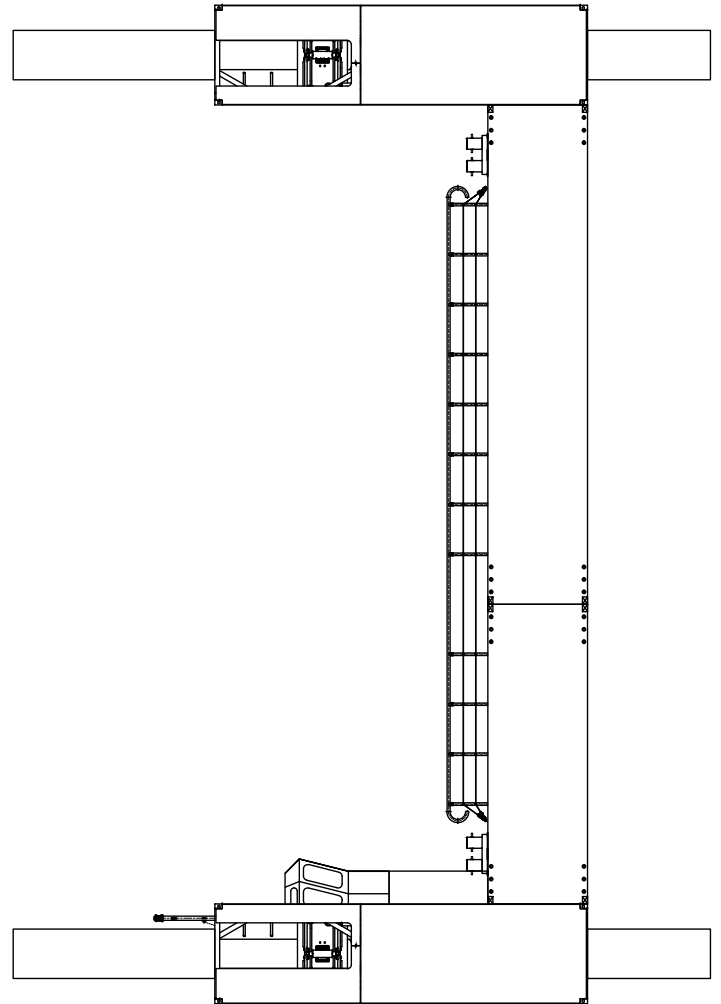
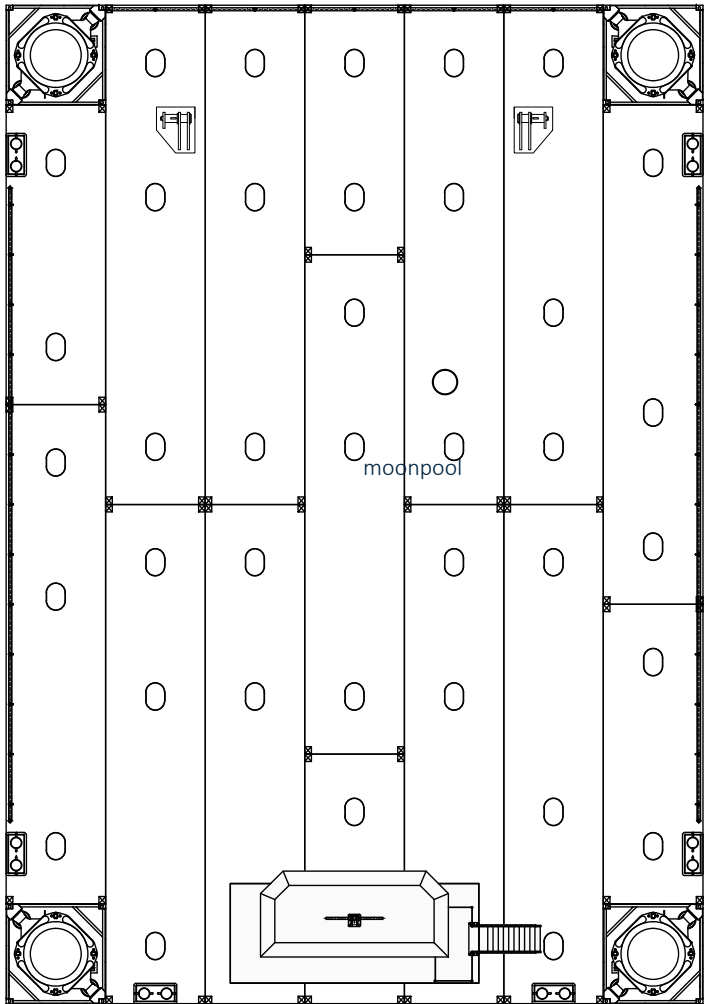
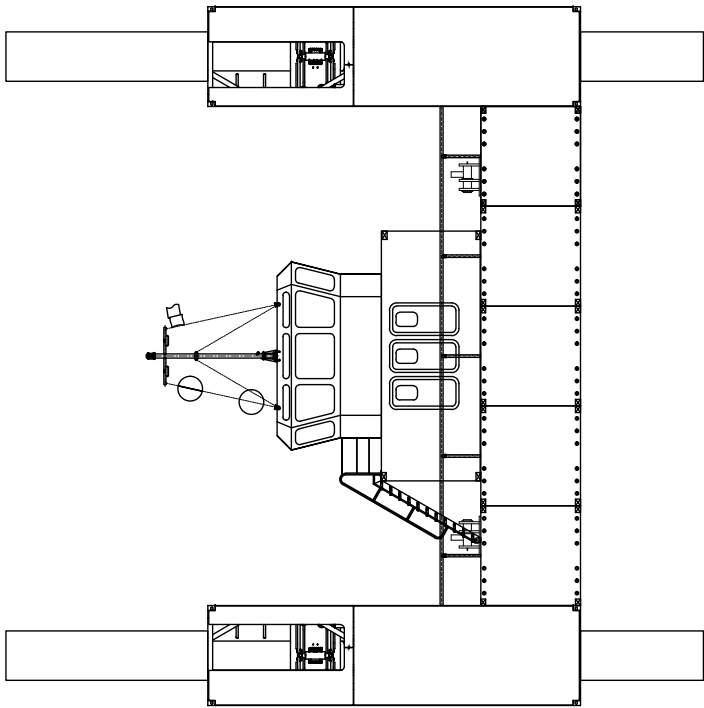

MultiJack-Up 2417 | Jack-up barge

For more information, please contact us on:

T +31 (0)184 621 423 E info@neptunmarine.com W www.neptunmarine.com

Version: V.01

