



MultiTug 2308 | Tugboat



Multi Tugs have proven their versatility and robustness at sea, over the years. The maximum free deck space for this type of multipurpose tugboat offers many possibilities for all kinds of operations including towing, anchor handling, dredging support and wind farm support.



CLASSIFICATION	Bureau Veritas I  HULL • MACH • AUT-UMS, TUG, Unrestricted Navigation, GMDSS Area A2		TANKS		
DIMENSIONS			FUEL OIL	50 m ³	
LENGTH O.A.	23,68 meters		FRESH WATER	22 m ³	
BREADTH MLD.	8,50 meters		DECK LAY-OUT		
DEPTH AT SIDE	3,25 meters		ANCHOR HANDLING / TOWING WINCH	60 ton split drum type	
DRAFT	2,65 meters		PULLING FORCE	50 ton at 1st layer	
GROSS TONNAGE	135		HAULING SPEED	5m/min – 15m/min	
NET TONNAGE	40		DECK	Azobé deck covering	
PERFORMANCES			TOWING HOOK	Mampaey 45 tons SWL Disc	
SPEED	10 knots		FENDERING	Tire- and optional D-fendering on the side, pushbow fendering fore ship, D-fendering aft ship	
BOLLARD PULL	14,0 tons		ACCOMMODATION		
PROPULSION			FACILITIES	Airconditioned accommodation for up to 6 persons.	
MAIN ENGINES	2x Caterpillar C18		OPTIONS		
TOTAL POWER	714 kW at 1800 RPM		DECK CRANE	Heila HLRM 65-4S	
PROPELLERS	1500 mm in nozzle		TUGGER WINCH	8 ton at 1 st layer	
AUXILIARIES			TOWING PINS	Aft ship set + chain stopper	
GENERATOR SETS	2x Caterpillar C7.1				
TOTAL E-POWER	236 kW				
HYDRAULIC POWER PACK	2x 55 kW – Electrical driven				

View_Deck_5920_04

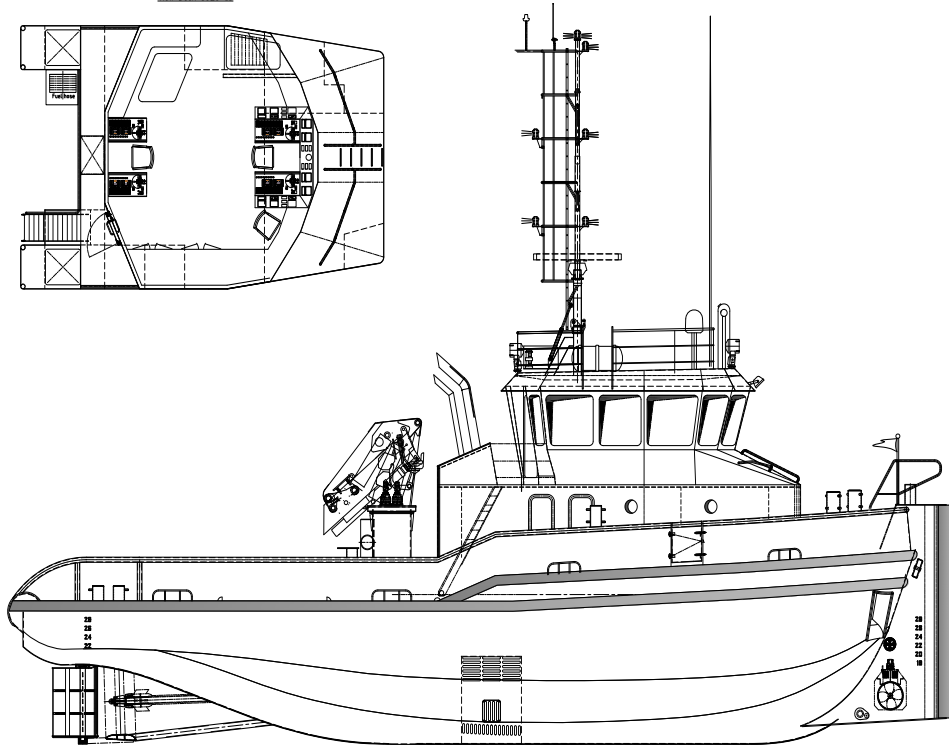
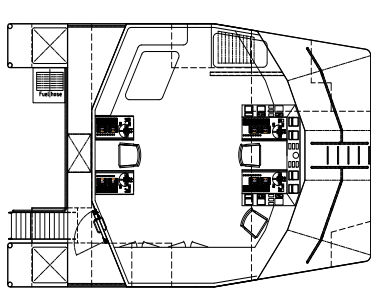

FRONTVIEW

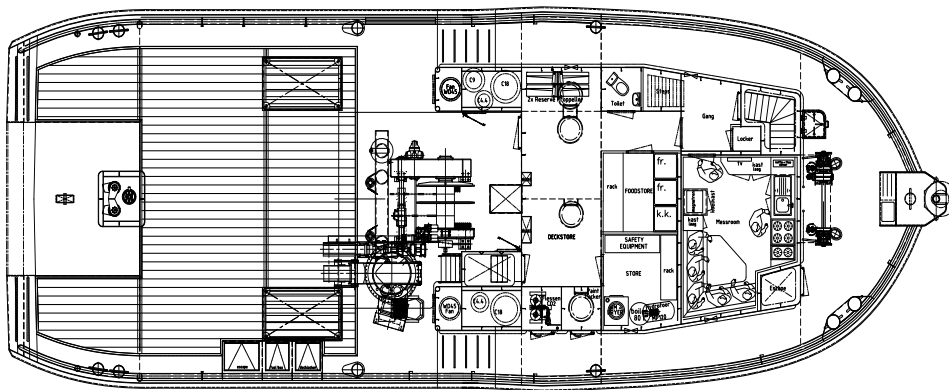
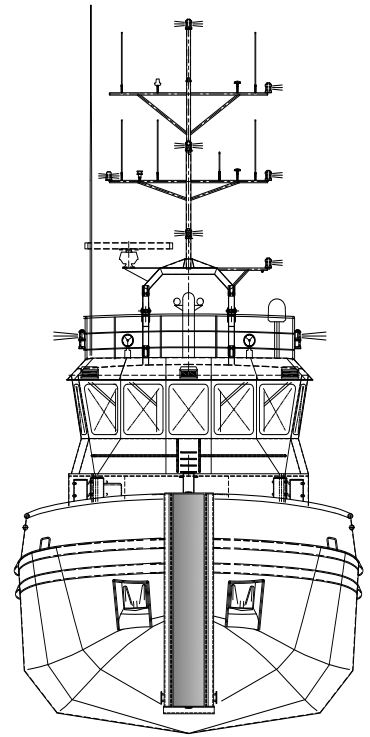

AFTVIEW

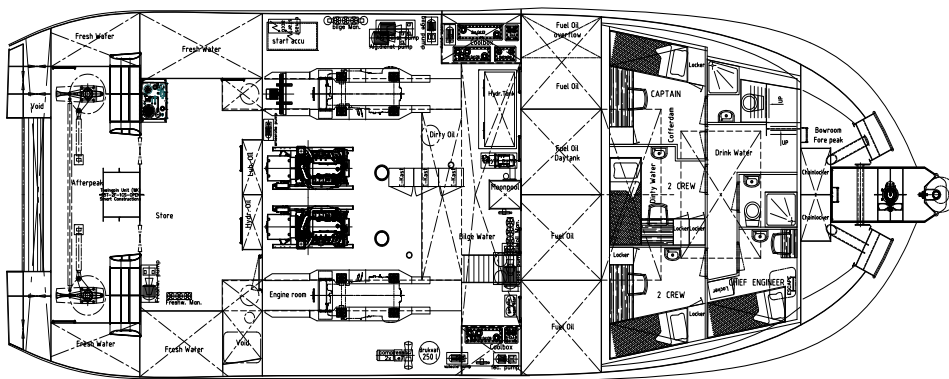
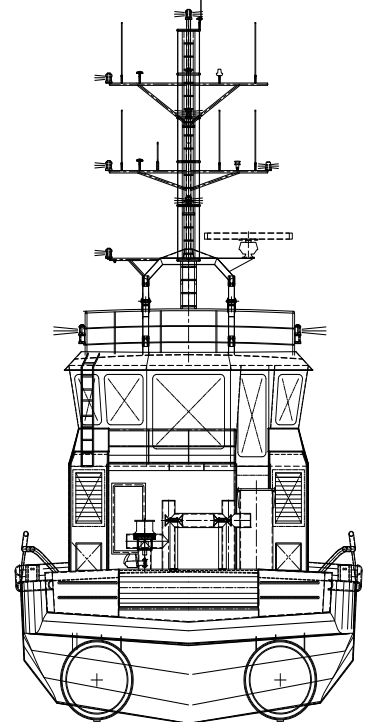

MultiTug 2308 | Tugboat

For more information, please contact us on:
T +31 (0)184 621 423 E info@neptunemarine.com W www.neptunemarine.com
Version: V.01

